



Customer	
Job Number	
Site Address	
Lift ID	
Delivery Date	

Information Provided by customer

Full Drawing Set	<input type="checkbox"/>
GA	<input type="checkbox"/>
Survey Details	<input type="checkbox"/>
Specification	<input type="checkbox"/>
Spec Sheet	<input type="checkbox"/>
Hand Sketches	<input type="checkbox"/>

Delivery Details

Bramptons Lift Manufacturers Ltd.
Unit 4 Boughton Road
Thamesmead
London
SE28 OAG

T: 0208 855 6779
F: 0208 855 0661
E: info@bramptons-ltd.co.uk
www.bramptons-ltd.co.uk

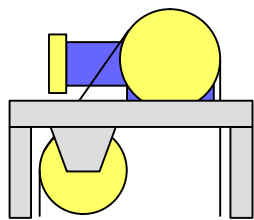

Configuration 1

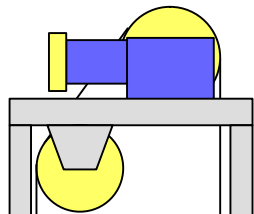
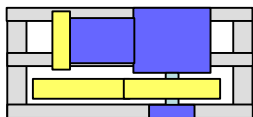

Configuration 2

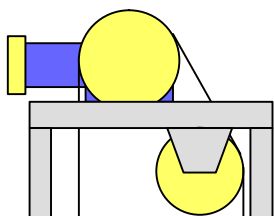

Configuration 3

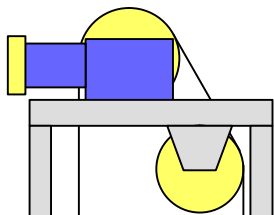
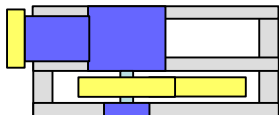

Configuration 4

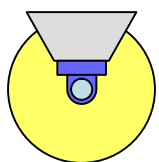
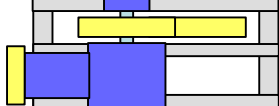

Type A Diverter

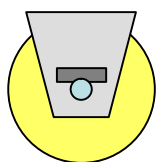

Type B Diverter

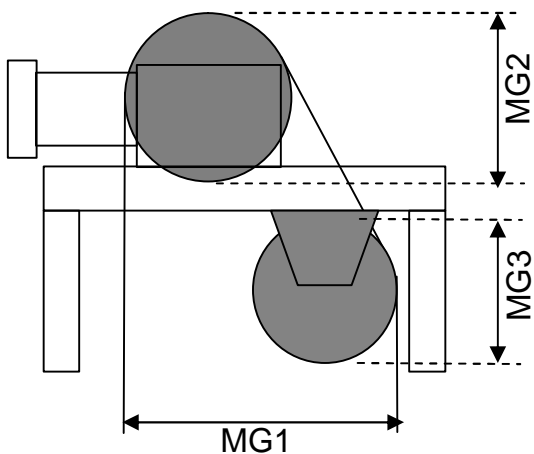

Machine manufacturer

Machine Model / Ref. No.

Diverter Ref. No.

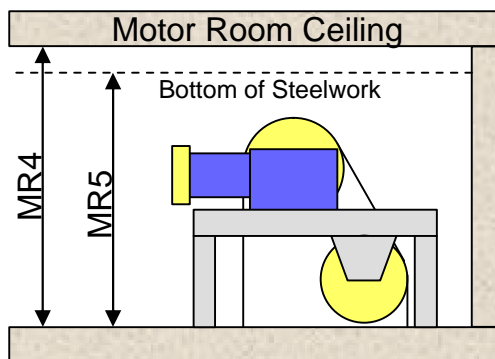
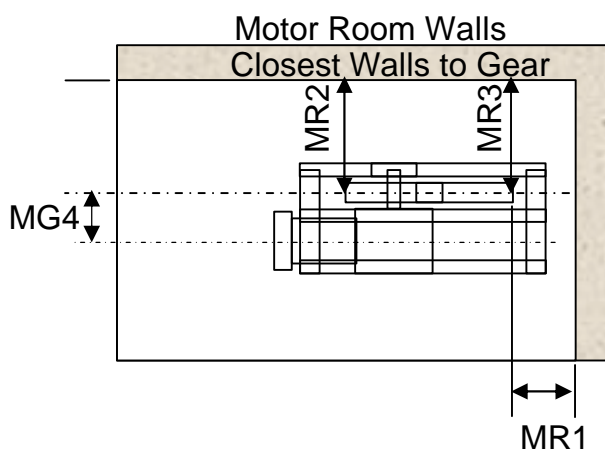

MG1	
MG2	
MG3	
MG4	
MR1	
MR2	
MR3	
MR4	
MR5	

For Gear Rafts mounted on Concrete Plinths, the following extra dimensions are required.

Please fill in Page 1 for Gear Raft, as well as this page.

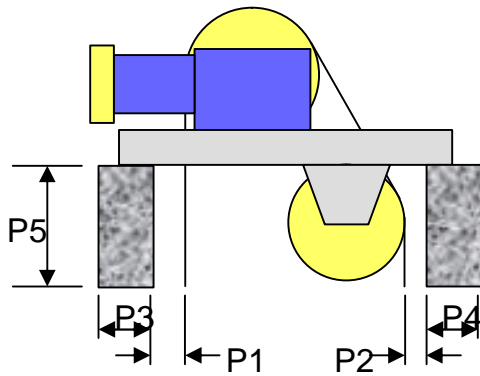

P1	
P2	
P3	
P4	
P5	
P6	
P7	
P8	

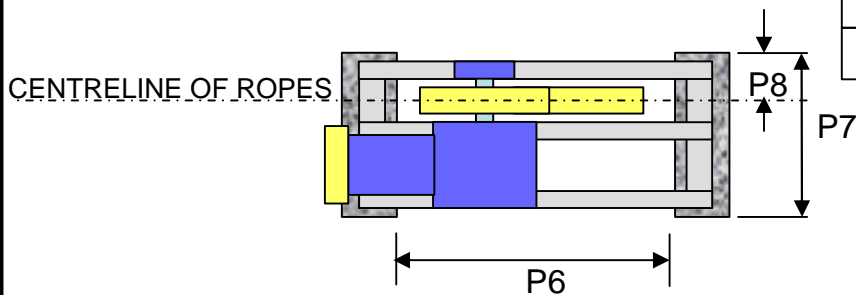

For Plinths with embedded fixing rails (Halfen Channel etc.), please add the following:

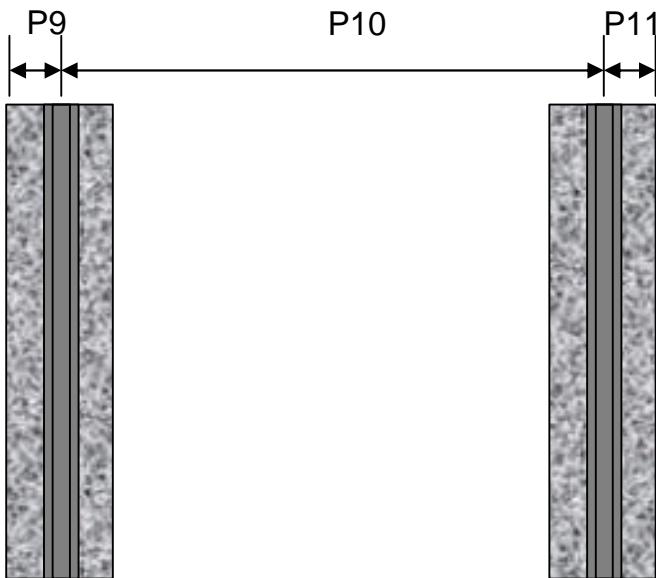

P9	
P10	
P11	